

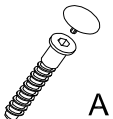

SZAFKA POD ZLEW 80
SKRINKA POD DREZ 80
SPÜLENUNTERSCHRANK 80
SINK 80
EVIER 80

											
8	8	1	2	4	10-15	4	4	8	4	2	2

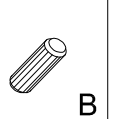
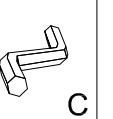
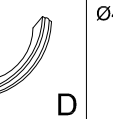
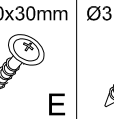
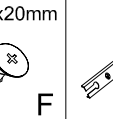
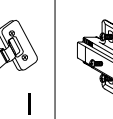
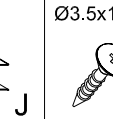
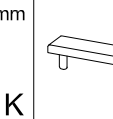
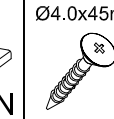
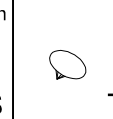

Pakował:

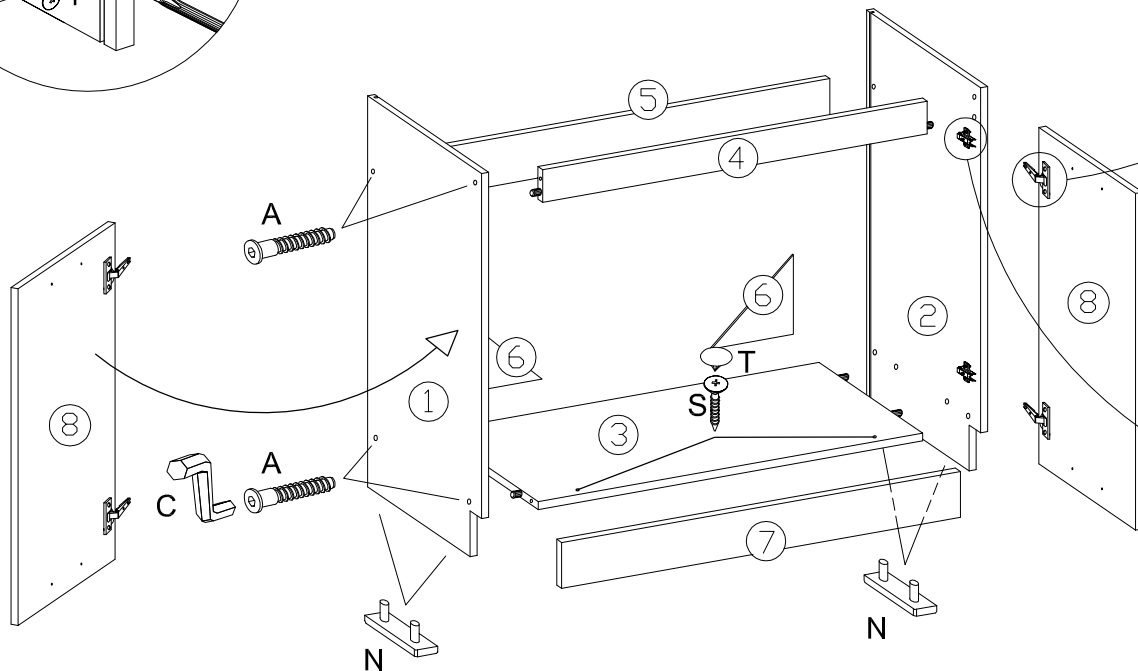
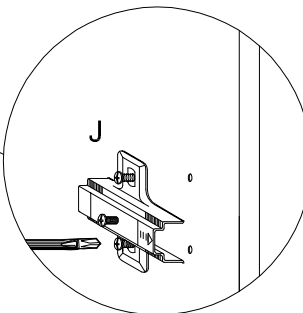
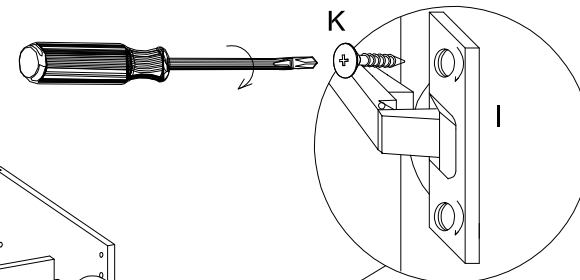
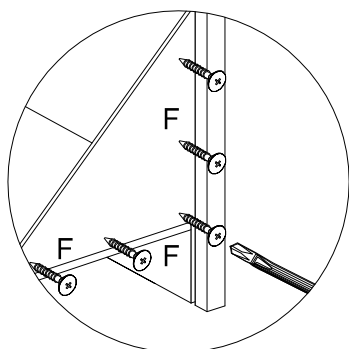
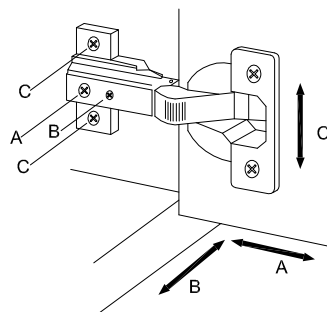
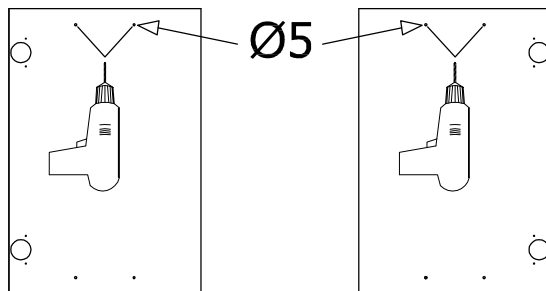
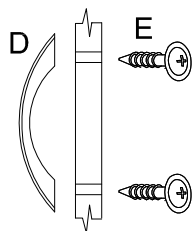
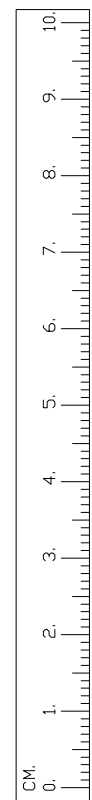
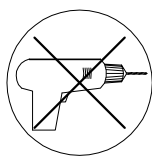
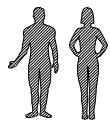
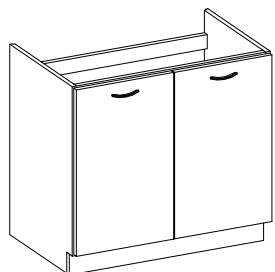
Szanowny kliencie.

W razie reklamacji jakościowej lub ilościowej proszę podać nr pakującego oraz nr elementu.

Achtung: Bei eventuellen Beanstandungen, bitten wir Sie die Nr. des packers sowie die, des fehlenden bzw. beschädigten Teiles unbedingt anzugeben.

Dragi kupci.









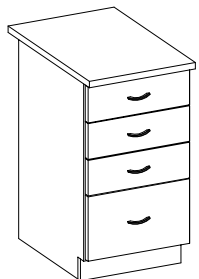

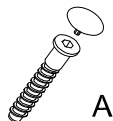
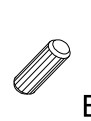
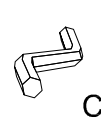
Prilikom eventualne reklamacije morate obavezno navesti broj pečata koji je na paketu i broj dijelova koji nedostaju ili su oštećeni u paketu. Jedino u tom slučaju možemo prihvatiti Vašu reklamaciju kao valjanu. Unaprijed Vam zahvaljuje Vaš.

Dear Customer.

We regret to inform you, that in time complaint please give No packer and No missing and spoil element.

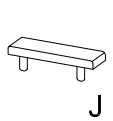
SZAFKA DOLNA Z SZUFLADAMI
SKRINKA DOLNÁ SO ZÁSUVKAMI
SCHUBKASTENSCHRANK
CASE WITH DRAWERS
BAS TIRORS

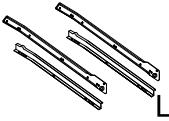

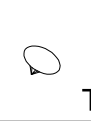

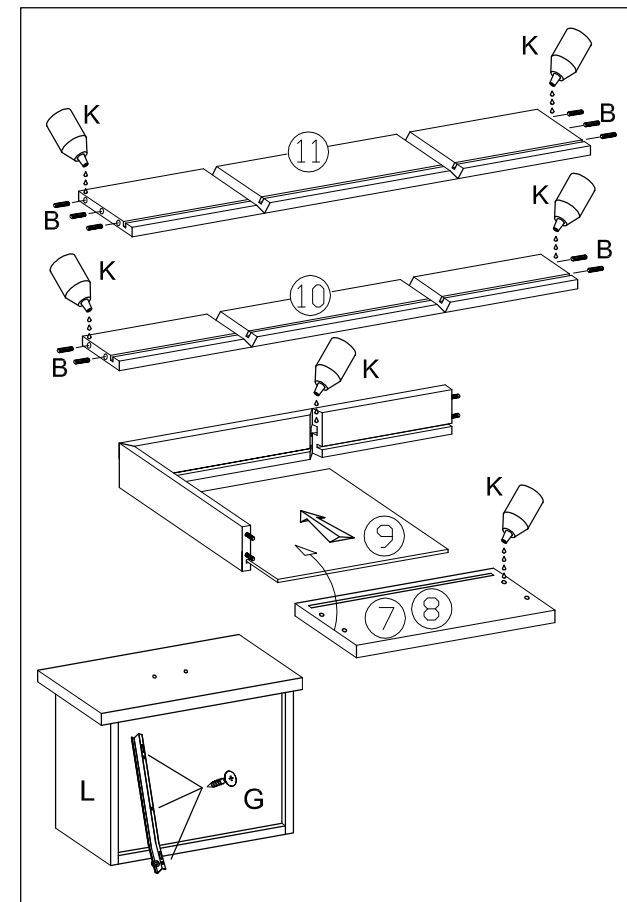
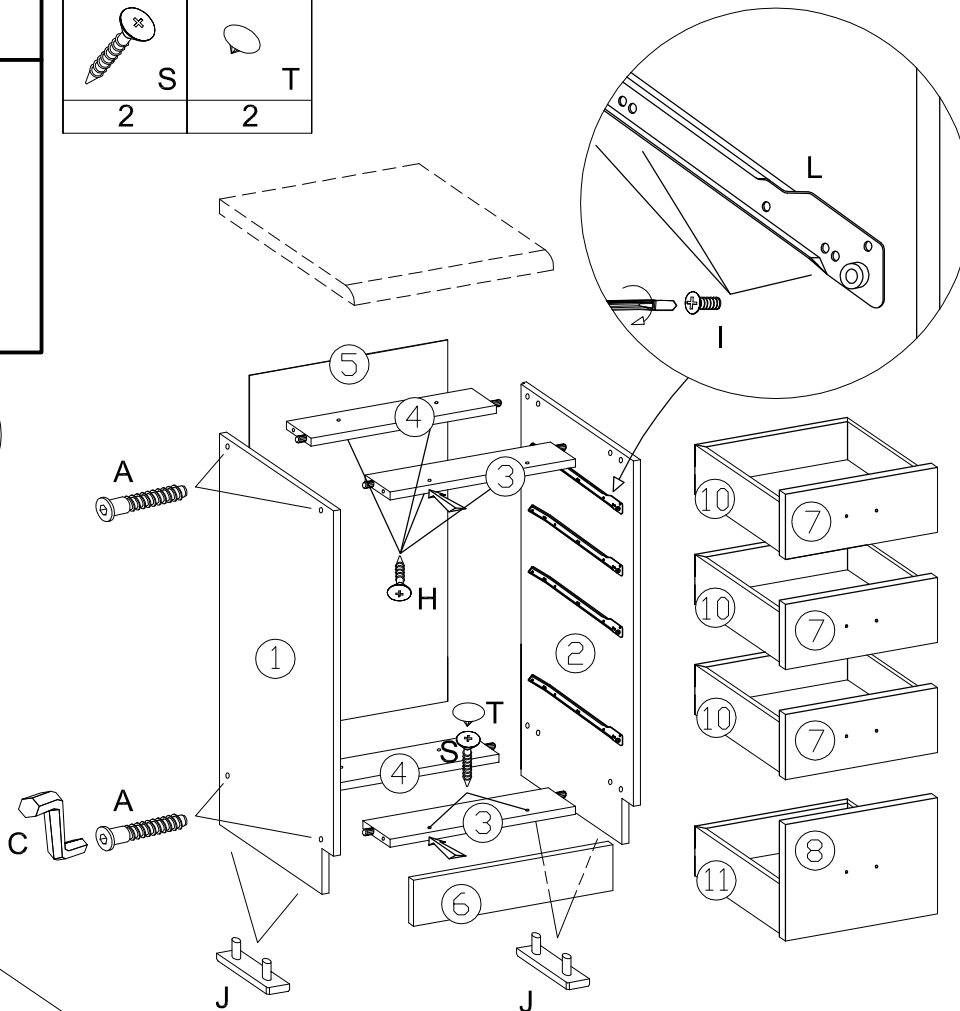
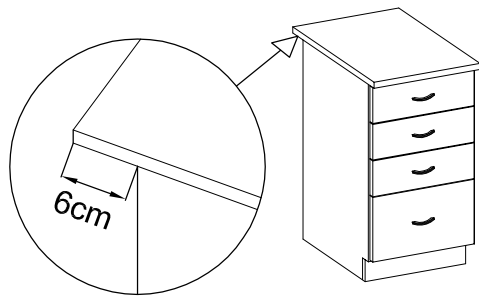
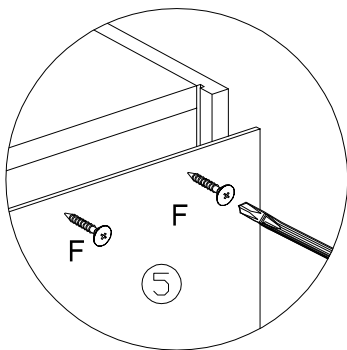
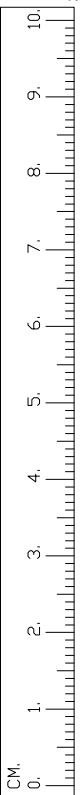
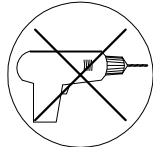
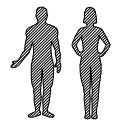





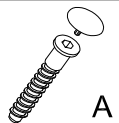





 A	 B	 C	 D	 E	 F	 G	 H	 I	 J	 K	 L
8	26	1	4	8	15-20	24	4	24	4	1	4
 S	 T										
2	2										



Pakował: Szanowny kliencie.
 W razie reklamacji jakościowej lub ilościowej proszę podać nr pakującego oraz nr elementu.
 Achtung: Bei eventuellen Beanstandungen, bitten wir Sie die Nr. des packers sowie die, des fehlenden bzw. beschädigten Teiles unbedingt anzugeben.
 Dragi kupci.
 Prilikom eventualne reklamacije morate obavezno navesti broj pečata koji je na paketu i broj dijelova koji nedostaju ili su oštećeni u paketu. Jedino u tom slučaju možemo prihvatiti Vašu reklamaciju kao valjanu. Unaprijed Vam zahvaljuje Vaš.
 Dear Customer.
 We regret to inform you, that in time complaint please give No packer and No missing and spoil element.

SZAFKA DOLNA 80
SKRINKA DOLNÁ 80
UNTERSCHRANK 80
BASE UNIT 80
BAS 80

 A	 B	 C	 D	 E	 F	 G	 H	 I	 J	 K	 N	 O
8	8	1	2	4	15-20	4	1	4	4	8	4	4
 S		 T										
2		2										

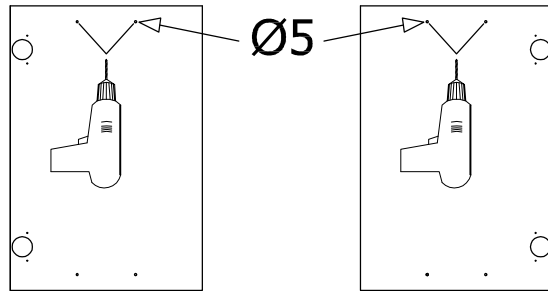
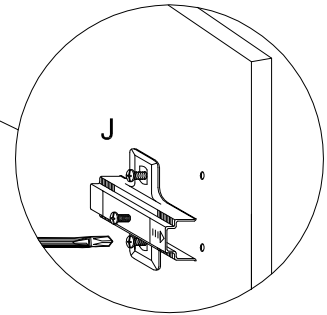
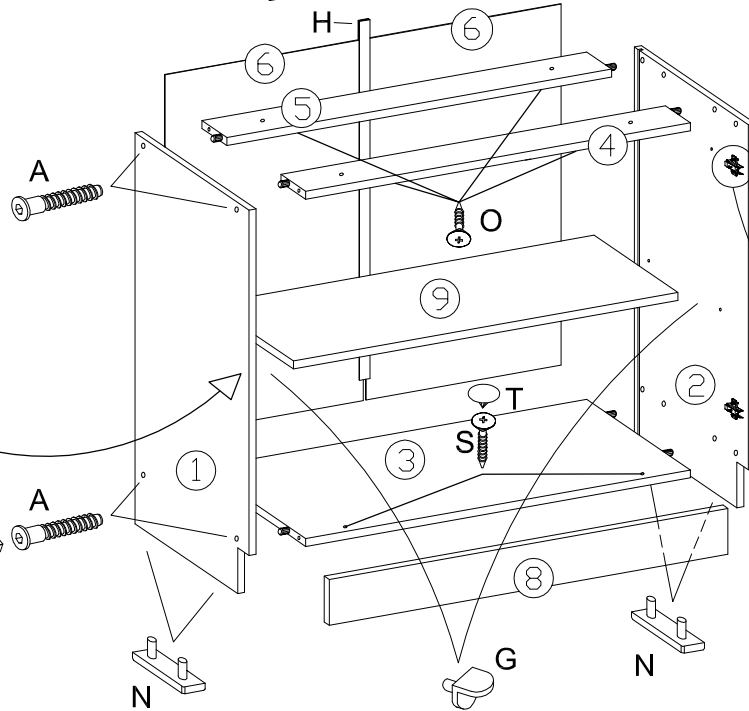
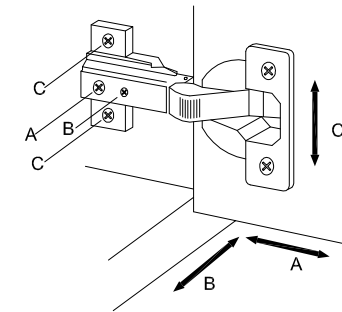
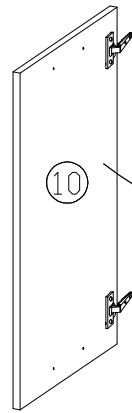
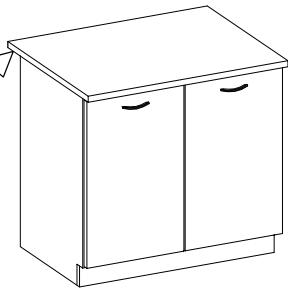
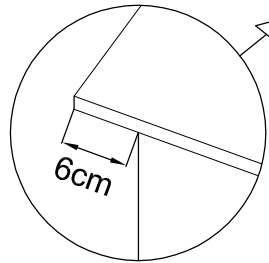
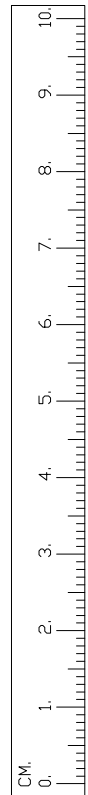
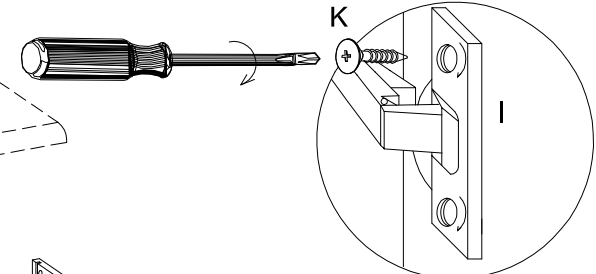
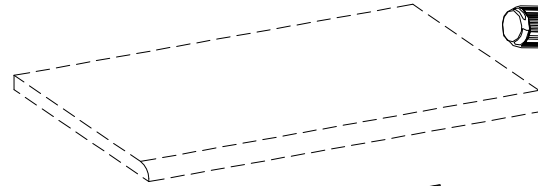
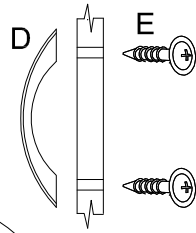
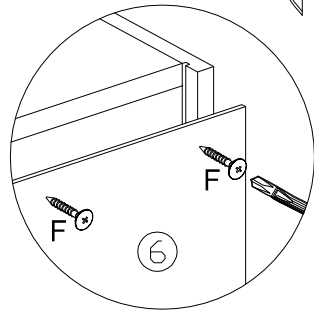
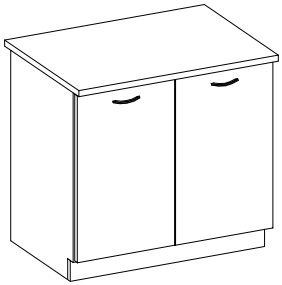

Pakował:

Szanowny kliencie.

W razie reklamacji jakościowej lub ilościowej proszę podać nr pakującego oraz nr elementu.

Achtung: Bei eventuellen Beanstandungen, bitten wir Sie die Nr. des packers sowie die, des fehlenden bzw. beschädigten Teiles unbedingt anzugeben.











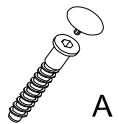

Dragi kupci.

Prilikom eventualne reklamacije morate obavezno navesti broj pečata koji je na paketu i broj dijelova koji nedostaju ili su oštećeni u paketu. Jedino u tom slučaju možemo prihvatiti Vašu reklamaciju kao valjanu. Unaprijed Vam zahvaljuje Vaš.

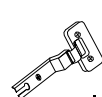
Dear Customer.

We regret to inform you, that in time complaint please give No packer and No missing and spoil element.

SZAFKA DOLNA 60
SKRINKA DOLNÁ 60
UNTERSCHRANK 60
BASE UNIT 60
BAS 60

 A	 B	 C	 D	 E Ø4.0x30mm	 F Ø3.0x20mm	 G	 I	 J	 K Ø3.5x13mm	 N	 O Ø4.0x35mm
8	8	1	2	4	15-20	4	4	4	8	4	4
 S Ø4.0x45mm	 T										
2	2										

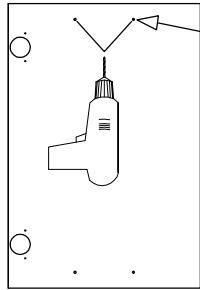
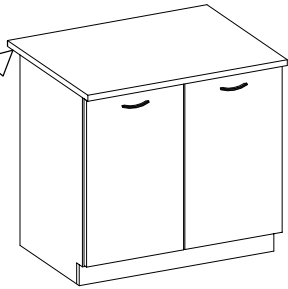
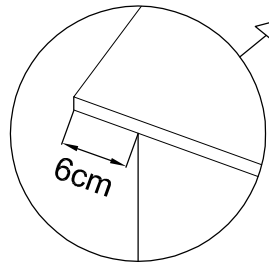
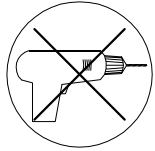
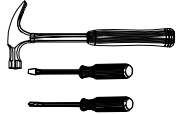
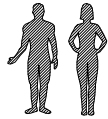
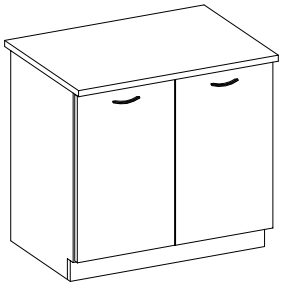

Ø5

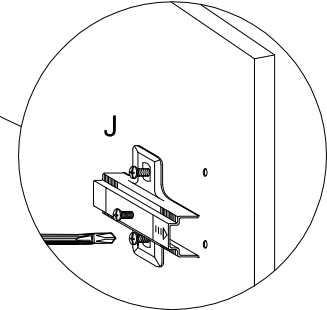
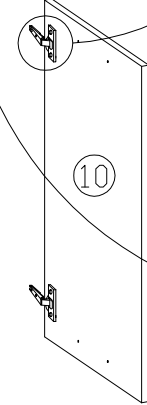
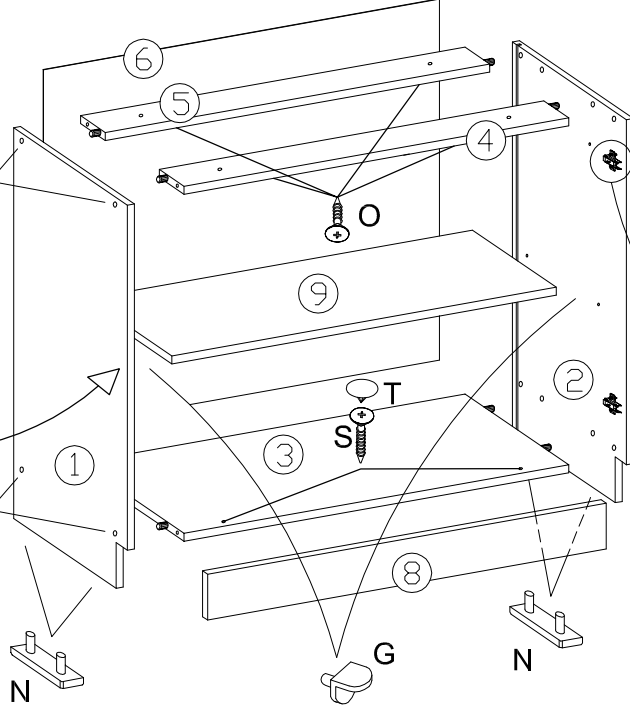
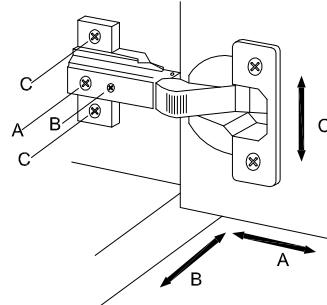
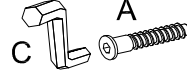
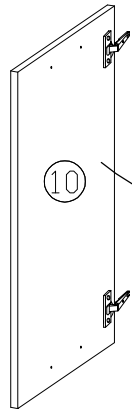
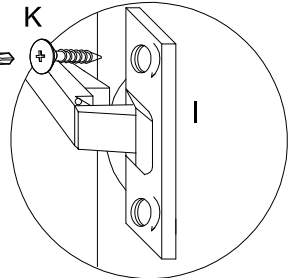
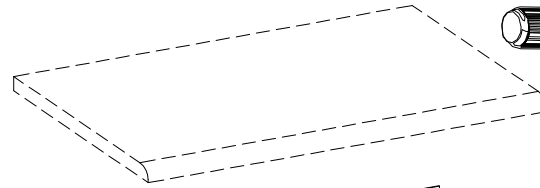
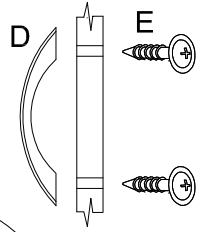
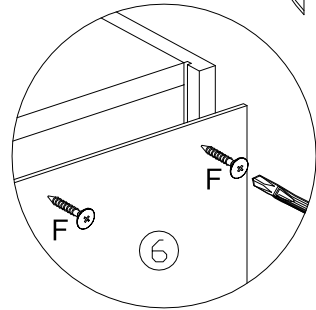
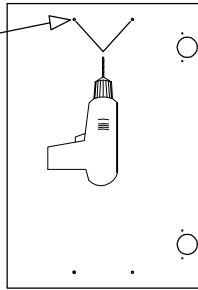







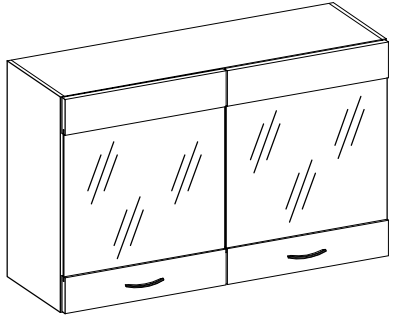

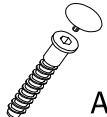
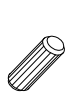
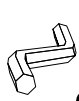

Pakował:

Szanowny kliencie.
 W razie reklamacji jakościowej lub ilościowej proszę podać nr pakującego oraz nr elementu.
 Achtung: Bei eventuellen Beanstandungen, bitten wir Sie die Nr. des packers sowie die, des fehlenden bzw. beschädigten Teiles unbedingt anzugeben.
 Dragi kupci.
 Prilikom eventualne reklamacije morate obavezno navesti broj pečata koji je na paketu i broj dijelova koji nedostaju ili su oštećeni u paketu. Jedino u tom slučaju možemo prihvatiti Vašu reklamaciju kao valjanu. Unaprijed Vam zahvaljuje Vaš.
 Dear Customer.
 We regret to inform you, that in time complaint please give No packer and No missing and spoil element.

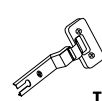
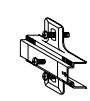
80 GS-72 2F

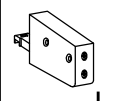

 A	 B	 C	 D	 E	 F	 G	 H	 I	 J	 K	 L	 M
8	8	1	2	4	15-20	8	1	4	4	8	2	4
0,05												
 O												
1												

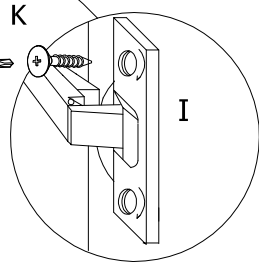
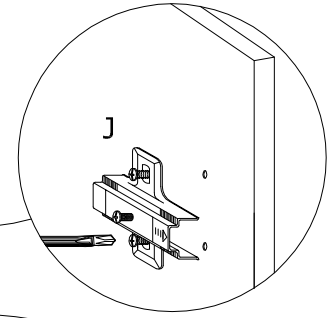
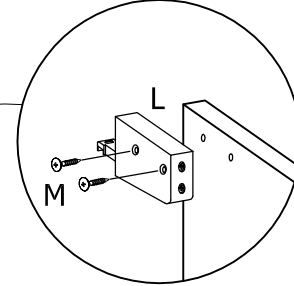
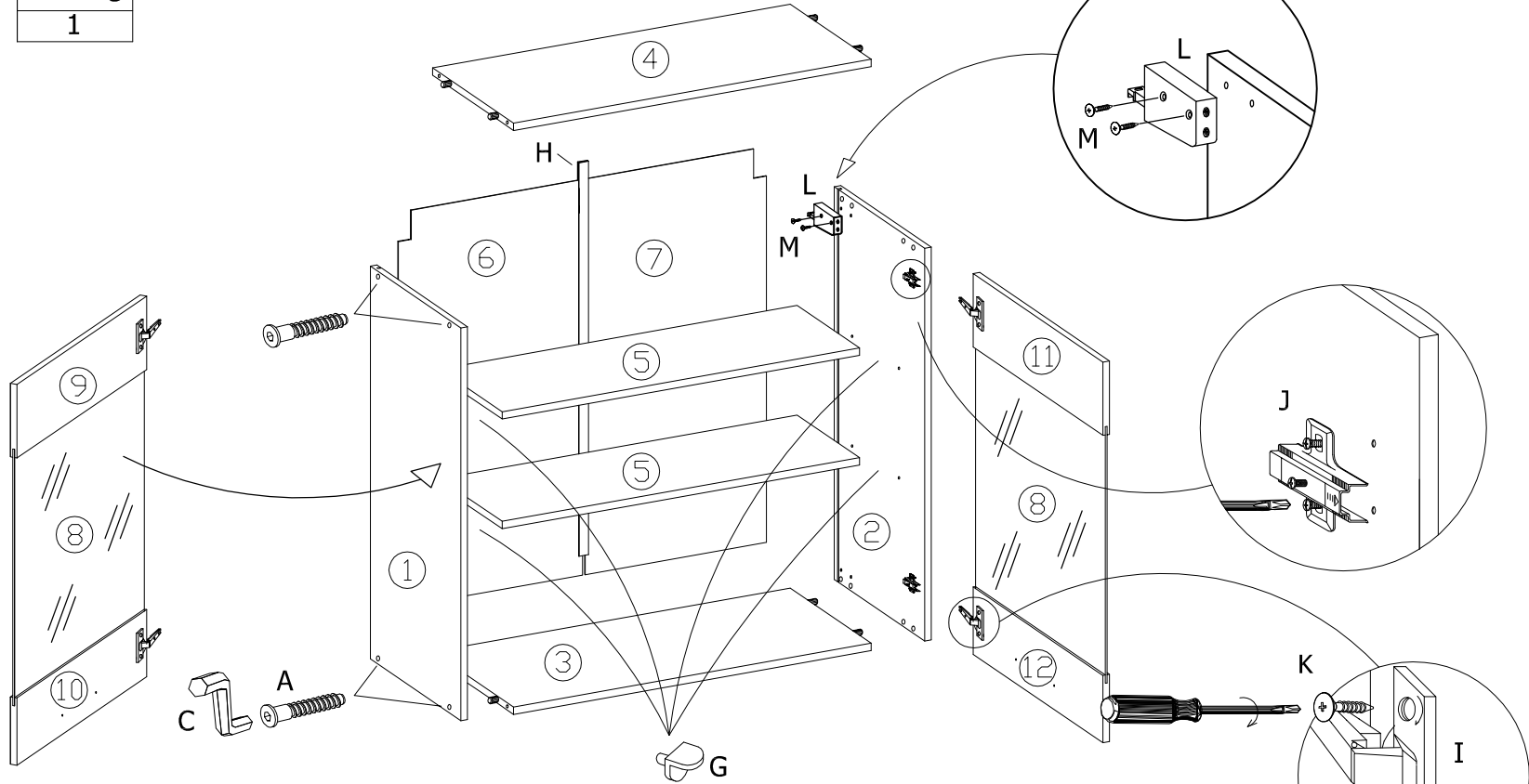
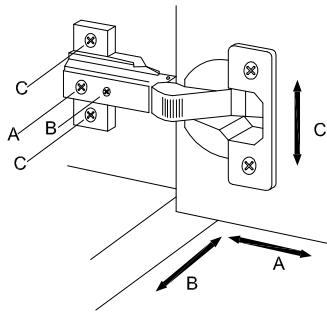
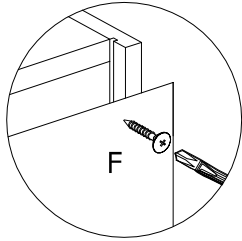
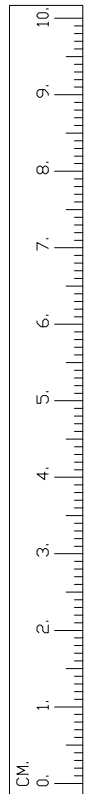
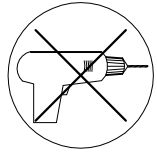
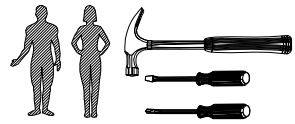



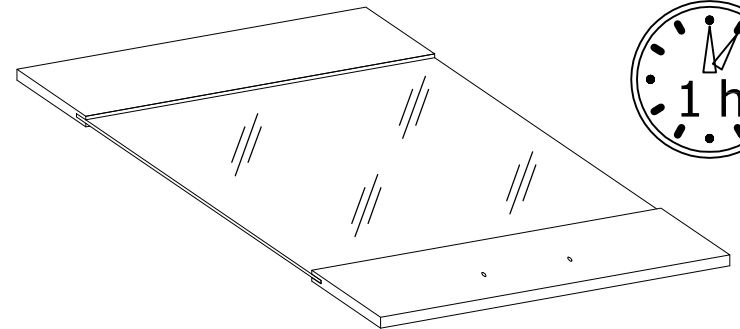
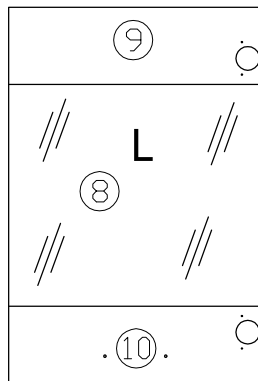
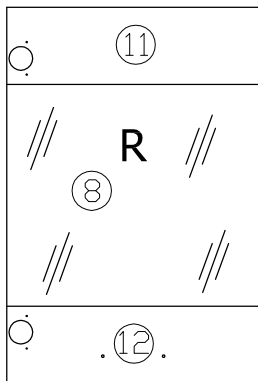
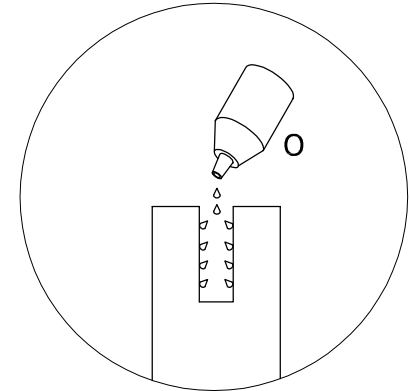
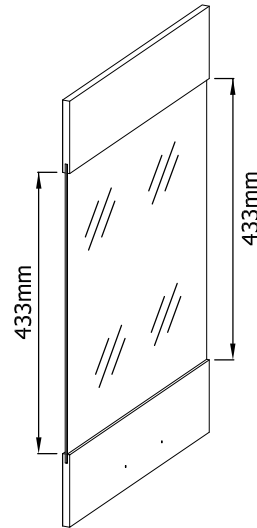
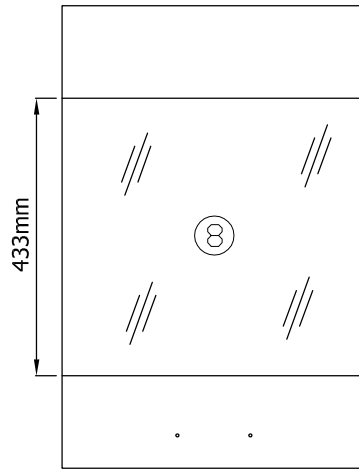
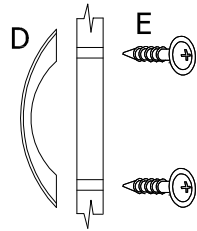
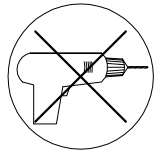
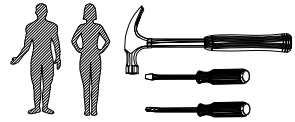
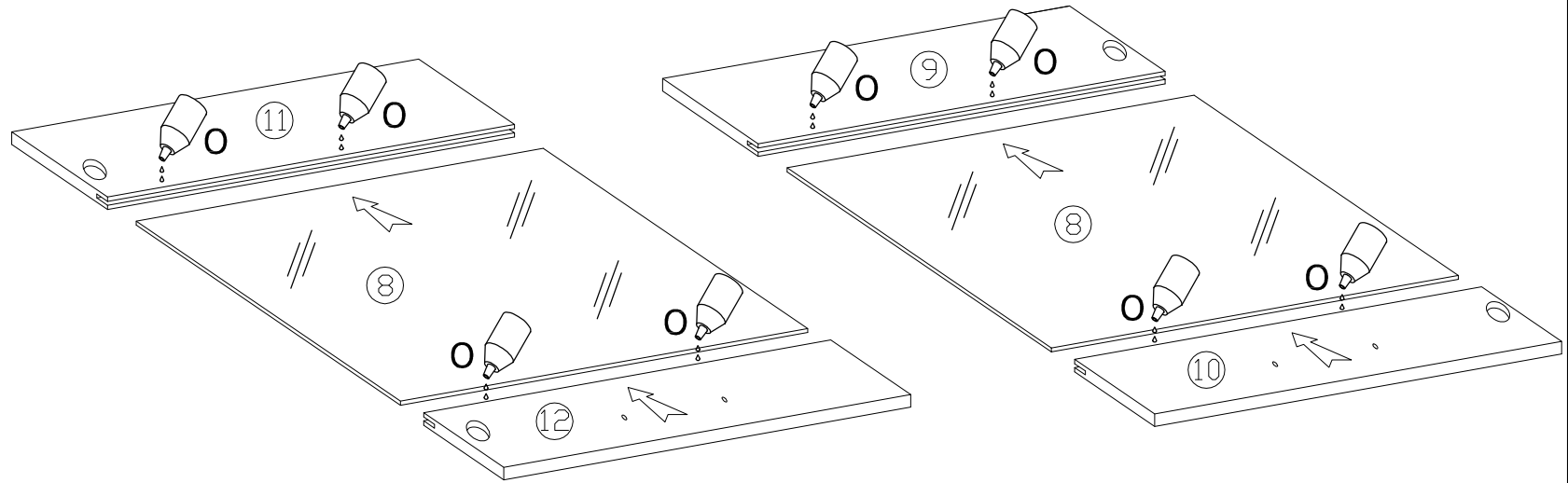
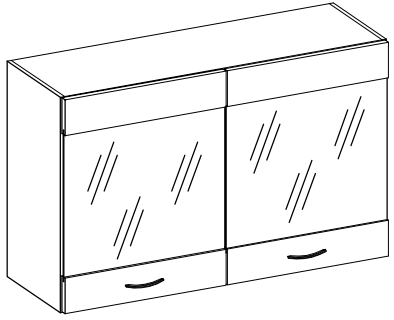



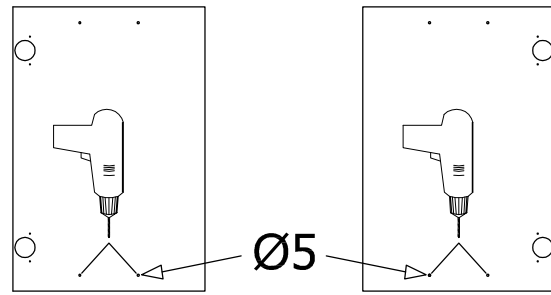
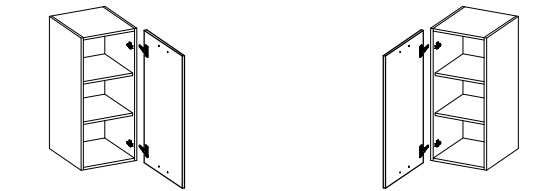
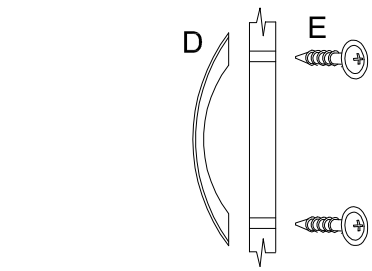
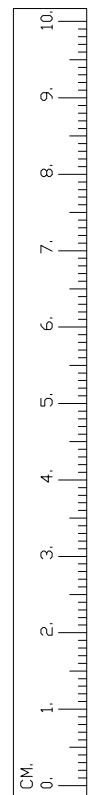
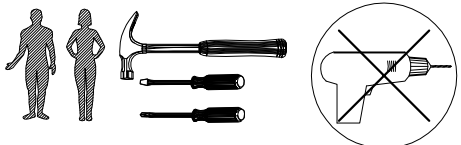
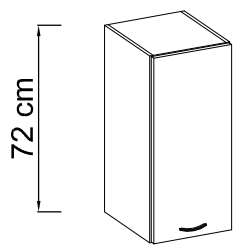

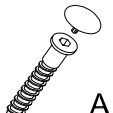
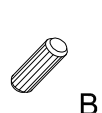
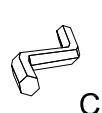
80 GS-72 2F

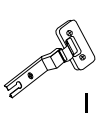
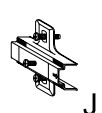

SZAFKA GÓRNA 30/40
SKRINKA HORNÁ 30/40
HÄNGESCHRANK 30/40
WALL UNIT 30/40
HAUT 30/40

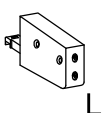



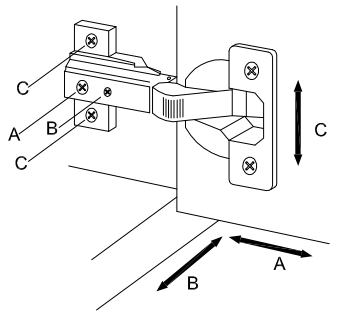
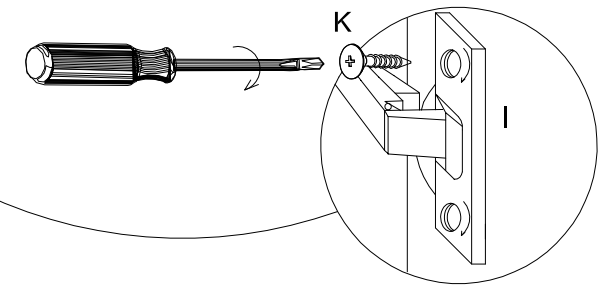
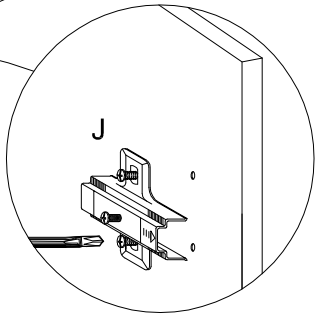
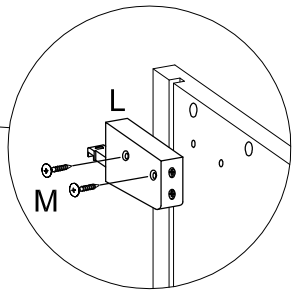
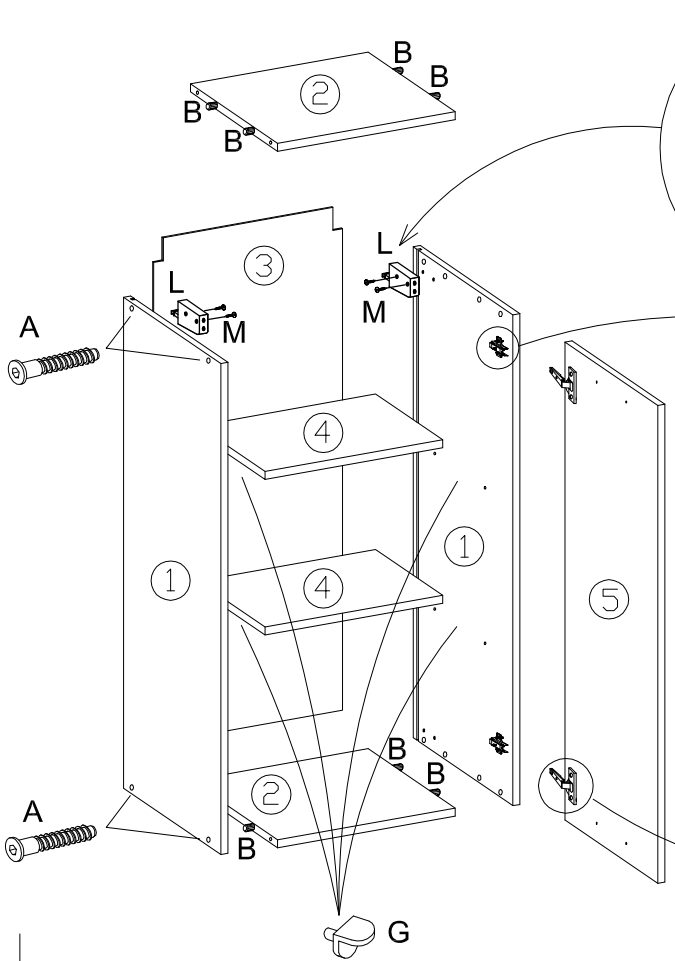
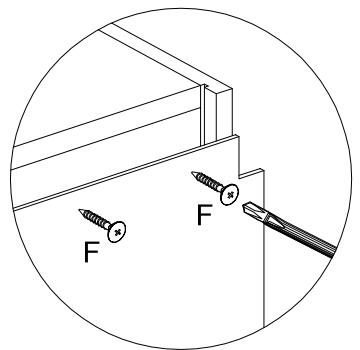







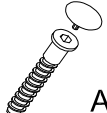

											
8	8	1	1	2	10-15	8	2	2	4	2	4

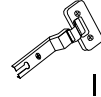

Pakował:

Szanowny kliencie.
 W razie reklamacji jakościowej lub ilościowej proszę podać nr pakującego oraz nr elementu.
 Achtung: Bei eventuellen Beanstandungen, bitten wir Sie die Nr. des packers sowie die, des fehlenden bzw. beschädigten Teiles unbedingt anzugeben.
 Dragi kupci.
 Prilikom eventualne reklamacije morate obavezno navesti broj pečata koji je na paketu i broj dijelova koji nedostaju ili su oštećeni u paketu. Jedino u tom slučaju možemo prihvatiti Vašu reklamaciju kao valjanu. Unaprijed Vam zahvaljuje Vaš.
 Dear Customer.
 We regret to inform you, that in time complaint please give No packer and No missing and spoil element.

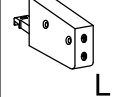
SZAFKA GÓRNA 80
SKRINKA HORNÁ 80
HÄNGESCHRANK 80
WALL UNIT 80
HAUT 80

												
8	8	1	2	4	10-15	8	1	4	4	8	2	4

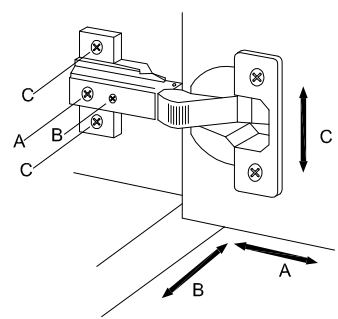
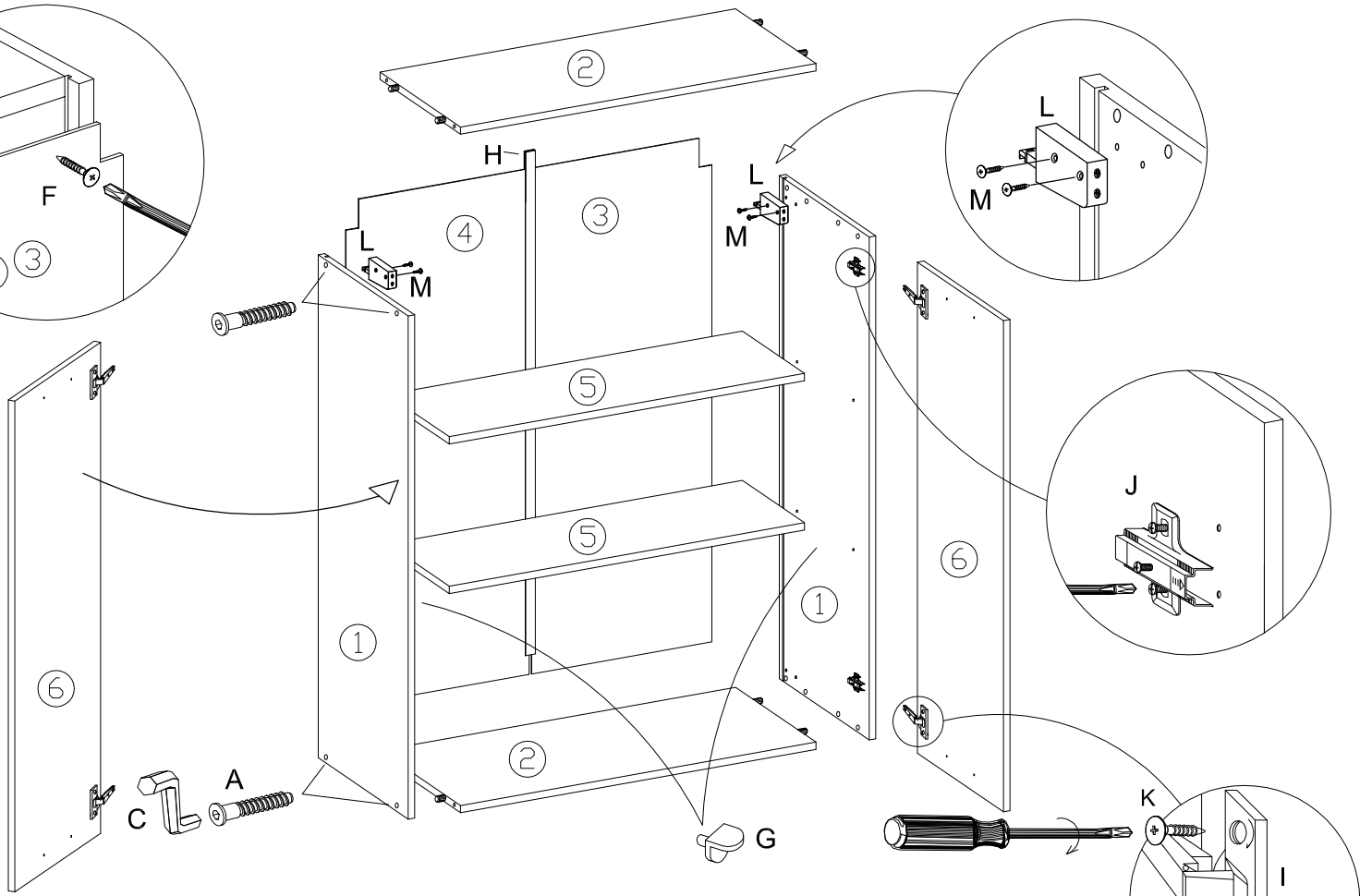
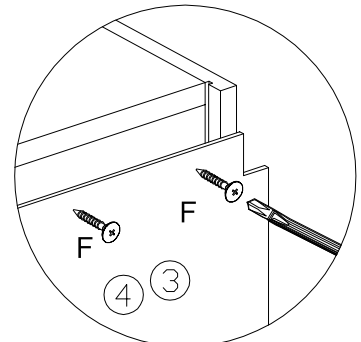
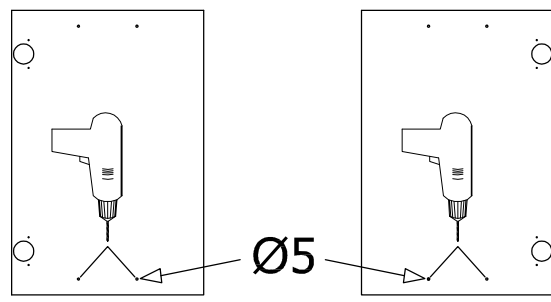
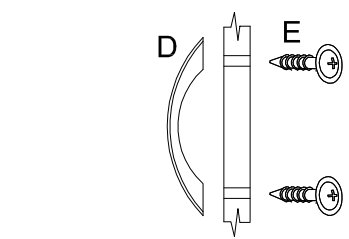
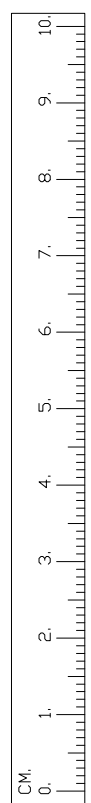
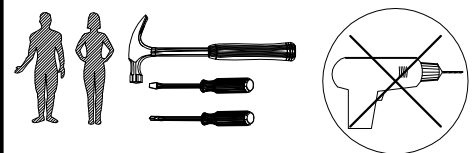
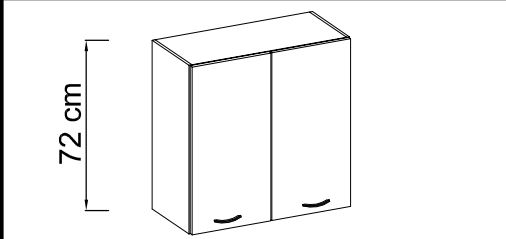

Pakował: Szanowny kliencie.
 W razie reklamacji jakościowej lub ilościowej proszę podać nr pakującego oraz nr elementu.
 Achtung: Bei eventuellen Beanstandungen, bitten wir Sie die Nr. des packers sowie die, des fehlenden bzw. beschädigten Teiles unbedingt anzugeben.
 Dragi kupci.
 Prilikom eventualne reklamacije morate obavezno navesti broj pečata koji je na paketu i broj dijelova koji nedostaju ili su oštećeni u paketu. Jedino u tom slučaju možemo prihvatiti Vašu reklamaciju kao valjanu. Unaprijed Vam zahvaljuje Vaš.
 Dear Customer.
 We regret to inform you, that in time complaint please give No packer and No missing and spoil element.

SZAFKA GÓRNA 60
 SKRINKA HORNÁ 60
 HÄNGESCHRANK 60
 WALL UNIT 60
 HAUT 60

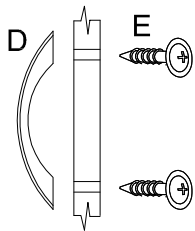
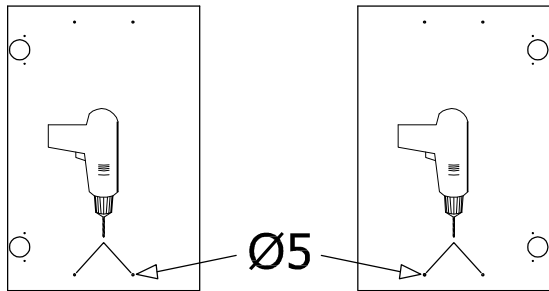
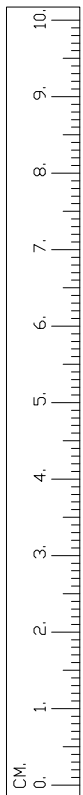
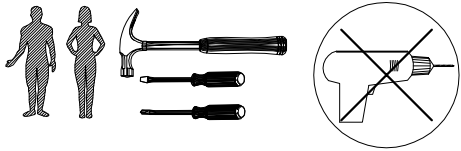
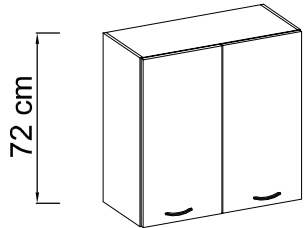

8	8	1	2	4	10-15	8	4	4	8	2	4

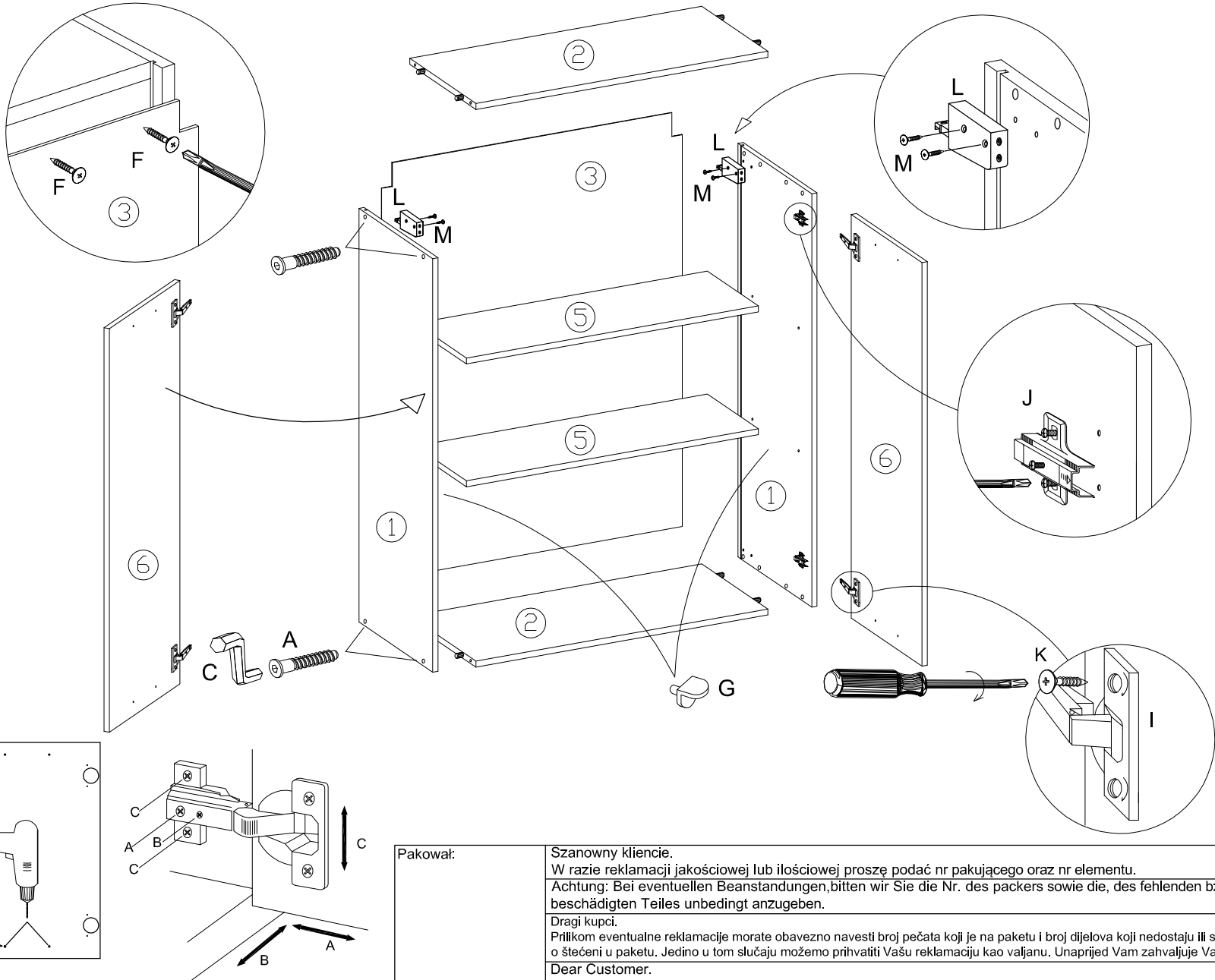

Pakował: Szanowny kliencie.
 W razie reklamacji jakościowej lub ilościowej proszę podać nr pakującego oraz nr elementu.
 Achtung: Bei eventuellen Beanstandungen, bitten wir Sie die Nr. des packers sowie die, des fehlenden bzw. beschädigten Teiles unbedingt anzugeben.
 Dragi kupci.
 Prilikom eventualne reklamacije morate obavezno navesti broj pečata koji je na paketu i broj dijelova koji nedostaju ili su oštećeni u paketu. Jedino u tom slučaju možemo prihvatiti Vašu reklamaciju kao valjanu. Unaprijed Vam zahvaljuje Vaš.
 Dear Customer.
 We regret to inform you, that in time complaint please give No packer and No missing and spoil element.